

# MAINTENANCE PARTS & FLUIDS

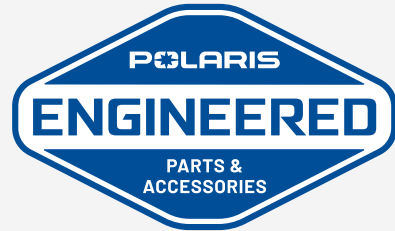

**POLARIS ENGINEERED PARTS AND OIL** have been validated and tested extensively, specifically for your vehicle. In order to maintain the peak performance of your Polaris vehicle only use official Polaris Engineered parts and oil.



We're taking the passion of our riders, workers, and outdoor enthusiasts to the next level with HD Parts. These Heavy Duty parts are engineered for riders who want greater durability and enhanced performance. HD Parts are designed and tested to handle greater wear and tear under all weather conditions.

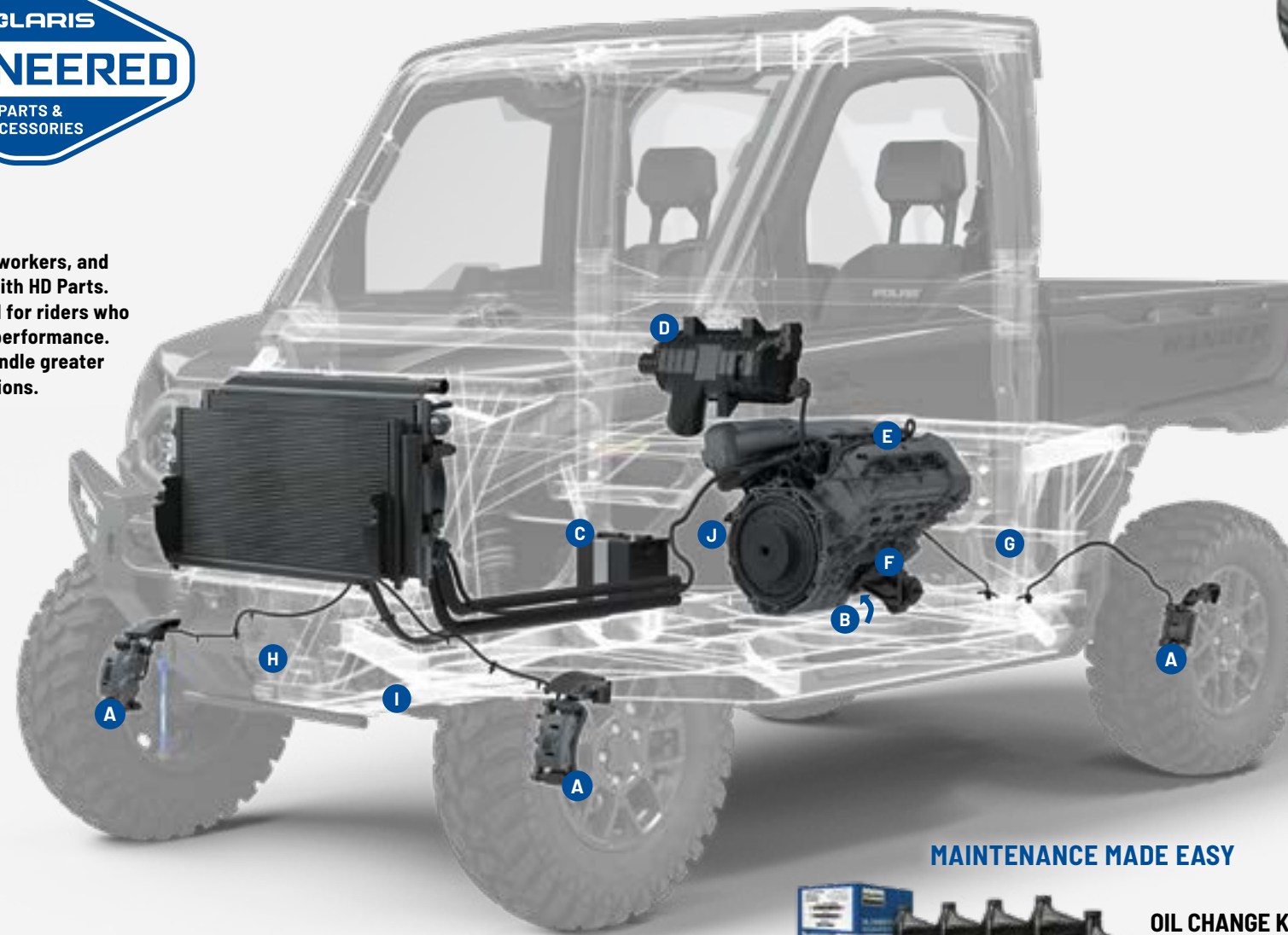

**A BRAKE PADS**  
» FRONT • 2209570  
» REAR • 2211902



**B OIL FILTER**  
» 2521728



**C BATTERY**  
» 4014132-P  
» **HD** • 4081855



**D AIR FILTER**  
» 7082115



**E SPARK PLUG**  
» 3023983

**LOOKING FOR MORE SERVICE PARTS?**  
See P. 133 to learn how to find parts for your model.



**F ENGINE OIL** P. 128  
» PS-4 • 1QT • 2876244  
» PS-4 • 1GAL. • 2876245  
» PS-4 EXTREME • 1QT • 2889395  
» PS-4 EXTREME • 1GAL. • 2889396



**G ANGLE DRIVE FLUID**  
For rear gearcase  
» 1QT • 2889280  
RANGER ANGLE DRIVE GEAR CASE SYSTEMS



**H DEMAND DRIVE FLUID**  
For front gearcase  
» 1QT • 2877922  
» 2.5 GAL. • 2877923



**I DOT 4 BRAKE FLUID**  
» 12 OZ • 2872189



**J STEELDRIVE TRANSMISSION FLUID**  
» 1QT • 2891094

## MAINTENANCE MADE EASY



**OIL CHANGE KITS**  
Engine Oil (volume varies by kit), 1 Oil Filter (2540086) & 1 Drain Plug Washer  
» PS-4 • 2890882  
» PS-4 EXTREME • 2890883



**ALL-SEASON GREASE TUBE**  
» 3 OZ • 2871322  
» 14 OZ • 2871423

Claims made based off testing and performance of Polaris HD Parts against standard OEM parts made by Polaris and competitor brands under normal use. For more information regarding Polaris HD parts including vehicle compatibility, installation and maintenance, please contact your authorized Polaris ORV dealer.

## MAINTENANCE SCHEDULE\*

### 12 MONTHS

200 HRS | 2,000 MI / 3,200 KM

- ENGINE OIL & OIL FILTER** CHANGE
- AIR FILTER** REPLACE
- BRAKE PADS** INSPECT  
REPLACE AS NEEDED
- SPARK PLUGS** INSPECT  
REPLACE AS NEEDED
- BATTERY** TEST & CLEAN  
REPLACE AS NEEDED
- FRONT & REAR GEARCASE** CHANGE FLUID
- GENERAL LUBRICATION** ALL FITTINGS, PIVOTS, CABLES, ETC.

### 24 MONTHS

400 HRS | 4,000 MI / 6,400 KM

- ENGINE OIL & OIL FILTER** CHANGE
- FRONT & REAR GEARCASE** CHANGE FLUID
- BRAKE FLUID** CHANGE
- ALTERNATOR BELT** REPLACE
- AIR FILTER** INSPECT  
REPLACE AS NEEDED
- BRAKE PADS** INSPECT  
REPLACE AS NEEDED
- SPARK PLUGS** INSPECT  
REPLACE AS NEEDED
- BATTERY** TEST & CLEAN  
REPLACE AS NEEDED
- GENERAL LUBRICATION** ALL FITTINGS, PIVOTS, CABLES, ETC.

### 36 MONTHS

600 HRS | 6,000 MI / 9,600 KM

- ENGINE OIL & OIL FILTER** CHANGE
- TRANSMISSION FLUID** CHANGE
- FRONT & REAR GEARCASE** CHANGE FLUID
- AIR FILTER** INSPECT  
REPLACE AS NEEDED
- BRAKE PADS** INSPECT  
REPLACE AS NEEDED
- SPARK PLUGS** INSPECT  
REPLACE AS NEEDED
- BATTERY** TEST & CLEAN  
REPLACE AS NEEDED
- GENERAL LUBRICATION** ALL FITTINGS, PIVOTS, CABLES, ETC.

FOR A COMPLETE MAINTENANCE SCHEDULE, CHECK YOUR OWNER'S MANUAL



\*This is a sample maintenance schedule and is not intended for use in your specific vehicle. Please reference and use your owners manual for proper maintenance and vehicle care.

# MAINTENANCE PARTS & FLUIDS

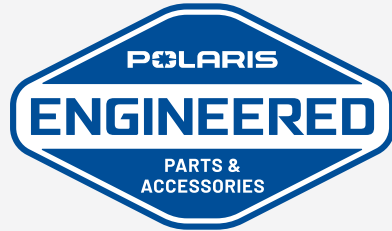

**POLARIS ENGINEERED PARTS AND OIL** have been validated and tested extensively, specifically for your vehicle. In order to maintain the peak performance of your Polaris vehicle only use official Polaris Engineered parts and oil.



We're taking the passion of our riders, workers, and outdoor enthusiasts to the next level with HD Parts. These Heavy Duty parts are engineered for riders who want greater durability and enhanced performance. HD Parts are designed and tested to handle greater wear and tear under all weather conditions.

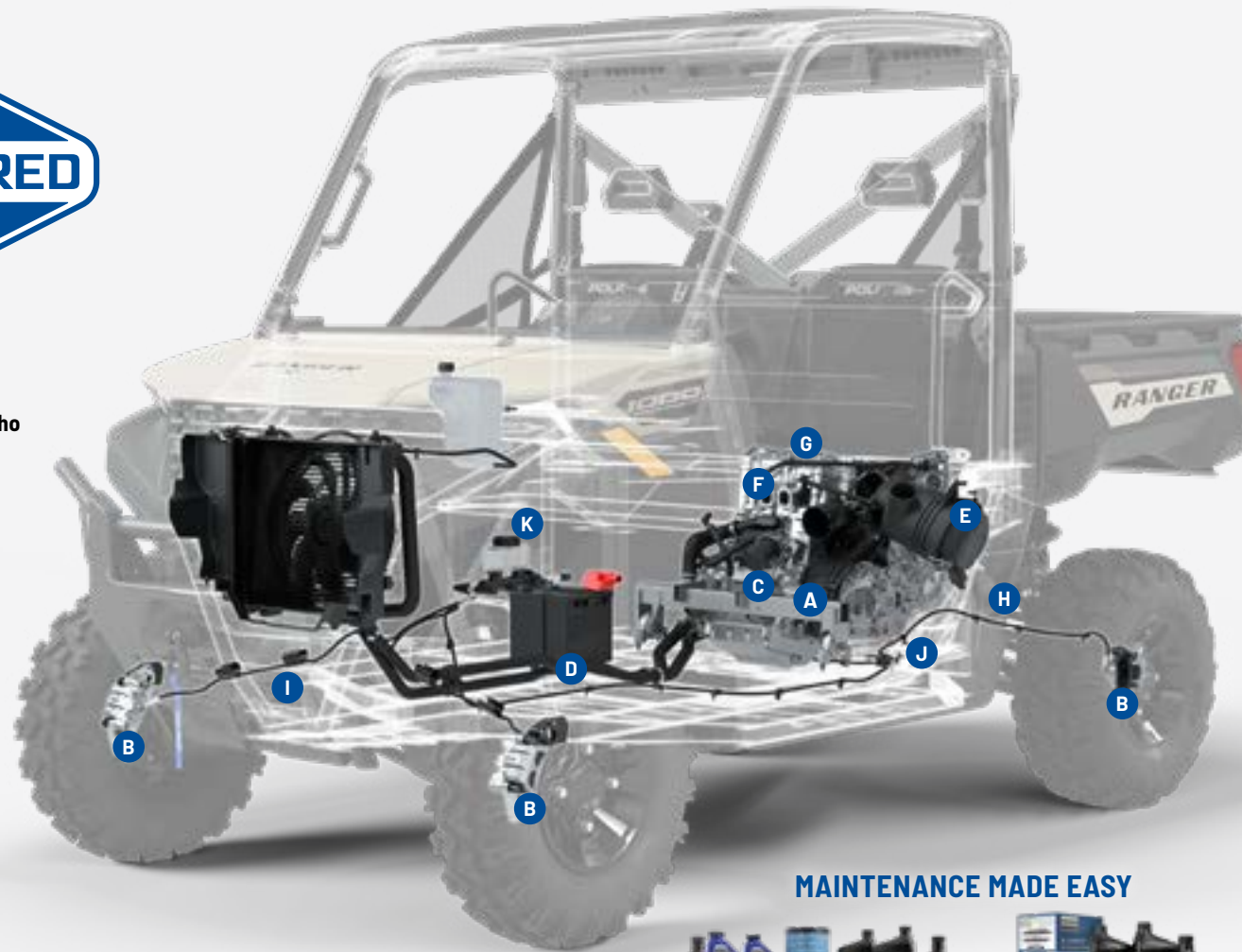

- A DRIVE BELT**
  - » 1000 • 3211218
  - » XP 1000 • 3211186
  - » XP 1000 • **HD** • 3212358
  - » XP KINETIC • 3212327
- B BRAKE PADS**
  - » FRONT • 2209279
  - » FRONT • **HD** • 2208933
  - » REAR • 2209280
  - » REAR • **HD** • 2208936
- C OIL FILTER**
  - » 2540086
  - » **HD** • 2522498
  - XP KINETIC DOES NOT HAVE AN OIL FILTER
- D BATTERY**
  - » 4014132-P
  - » **HD** • 4081855
- E AIR FILTER**
  - » 7082265
  - 1000 / XP 1000
  - » **HD** • 7083113
  - 1000 / XP 1000
- F SPARK PLUGS**
  - » 1000 • 3023571
  - » XP 1000 • 3022662

**LOOKING FOR MORE SERVICE PARTS?**  
See P. 133 to learn how to find parts for your model.

## MAINTENANCE MADE EASY



**ORV MAINTENANCE KIT**  
Includes Oil Change Kit, Gearcase Fluids, Air Filter, & Spark Plug  
» 2830556  
XP 1000 '18-26



**OIL CHANGE KITS**  
2.5 QT Engine Oil (oil varies by kit), 1 Oil Filter (2540086) & 1 Drain Plug Washer  
» PS-4 • 2879323  
» PS-4 EXTREME • 2890057  
NOT COMPATIBLE WITH XP KINETIC



**G ENGINE OIL** P. 128  
» PS-4 • 1 QT • 2876244  
» PS-4 • 1 GAL. • 2876245  
» PS-4 EXTREME • 1 QT • 2889395  
» PS-4 EXTREME • 1 GAL. • 2889396  
NOT COMPATIBLE WITH XP KINETIC



**H ANGLE DRIVE FLUID**  
For rear gearcase  
» 1 QT • 2889280  
ONLY COMPATIBLE WITH XP KINETIC



**I DEMAND DRIVE FLUID**  
For front gearcase  
» 1 QT • 2877922  
» 2.5 GAL. • 2877923



**J AGL**  
For transmission  
» 1 QT • 2878068  
» 1 GAL. • 2878069  
» EXTREME • 1 QT • 2891028



**K DOT 4 BRAKE FLUID**  
» 12 OZ • 2872189



**ALL-SEASON GREASE TUBE**  
» 3 OZ • 2871322  
» 14 OZ • 2871423

## MAINTENANCE SCHEDULE\*

RANGER 1000 / XP 1000

RANGER XP KINETIC

BREAK-IN MAINTENANCE	12 MONTHS	24 MONTHS	36 MONTHS	EVERY 1,000 MILES	EVERY 2,000 MILES
<b>FIRST 25 HRS   500 MI / 800 KM</b>	<b>200 HRS   2,000 MI / 3,200 KM</b>	<b>400 HRS   4,000 MI / 6,400 KM</b>	<b>600 HRS   6,000 MI / 9,700 KM</b>	<b>1,600 KM</b>	<b>3,200 KM</b>
<ul style="list-style-type: none"> <li><b>ENGINE OIL &amp; OIL FILTER CHANGE</b></li> <li><b>FRONT GEARCASE INSPECT FLUID</b></li> <li><b>BRAKE PADS INSPECT</b> <small>REPLACE AS NEEDED</small></li> <li><b>BRAKE FLUID INSPECT</b> <small>ADD FLUID AS NEEDED</small></li> <li><b>TRANSMISSION FLUID INSPECT</b> <small>ADD FLUID AS NEEDED</small></li> </ul>	<ul style="list-style-type: none"> <li><b>ENGINE OIL &amp; OIL FILTER CHANGE</b></li> <li><b>TRANSMISSION FLUID CHANGE FLUID</b></li> <li><b>FRONT GEARCASE CHANGE FLUID</b></li> <li><b>AIR FILTER REPLACE</b></li> <li><b>BRAKE PADS INSPECT</b> <small>REPLACE AS NEEDED</small></li> <li><b>DRIVE BELT INSPECT</b> <small>REPLACE AS NEEDED</small></li> </ul>	<ul style="list-style-type: none"> <li><b>ENGINE OIL &amp; OIL FILTER CHANGE</b></li> <li><b>TRANSMISSION FLUID CHANGE FLUID</b></li> <li><b>AIR FILTER REPLACE</b></li> <li><b>BRAKE FLUID CHANGE</b></li> <li><b>FRONT GEARCASE CHANGE FLUID</b></li> <li><b>BRAKE PADS INSPECT</b> <small>REPLACE AS NEEDED</small></li> </ul>	<ul style="list-style-type: none"> <li><b>ENGINE OIL &amp; OIL FILTER CHANGE</b></li> <li><b>TRANSMISSION FLUID CHANGE FLUID</b></li> <li><b>AIR FILTER REPLACE</b></li> <li><b>BRAKE PADS INSPECT</b> <small>REPLACE AS NEEDED</small></li> <li><b>FRONT GEARCASE CHANGE FLUID</b></li> </ul>	<ul style="list-style-type: none"> <li><b>TRANSMISSION FLUID CHANGE FLUID</b></li> <li><b>FRONT GEARCASE CHANGE FLUID</b></li> <li><b>BRAKE PADS INSPECT</b> <small>REPLACE AS NEEDED</small></li> <li><b>BATTERY TEST &amp; CLEAN</b> <small>REPLACE AS NEEDED</small></li> <li><b>GENERAL LUBRICATION ALL FITTINGS, PIVOTS, CABLES, ETC.</b></li> </ul>	<ul style="list-style-type: none"> <li><b>TRANSMISSION FLUID CHANGE</b></li> <li><b>FRONT GEARCASE CHANGE FLUID</b></li> <li><b>BRAKE FLUID CHANGE</b></li> <li><b>BRAKE PADS INSPECT</b> <small>REPLACE AS NEEDED</small></li> <li><b>BATTERY TEST &amp; CLEAN</b> <small>REPLACE AS NEEDED</small></li> <li><b>GENERAL LUBRICATION ALL FITTINGS, PIVOTS, CABLES, ETC.</b></li> </ul>
		<ul style="list-style-type: none"> <li><b>DRIVE BELT INSPECT</b> <small>REPLACE AS NEEDED</small></li> <li><b>SPARK PLUGS INSPECT</b> <small>REPLACE AS NEEDED</small></li> <li><b>BATTERY TEST &amp; CLEAN</b> <small>REPLACE AS NEEDED</small></li> <li><b>GENERAL LUBRICATION ALL FITTINGS, PIVOTS, CABLES, ETC.</b></li> </ul>	<ul style="list-style-type: none"> <li><b>DRIVE BELT INSPECT</b> <small>REPLACE AS NEEDED</small></li> <li><b>SPARK PLUGS INSPECT</b> <small>REPLACE AS NEEDED</small></li> <li><b>BATTERY TEST &amp; CLEAN</b> <small>REPLACE AS NEEDED</small></li> <li><b>GENERAL LUBRICATION ALL FITTINGS, PIVOTS, CABLES, ETC.</b></li> </ul>		



FOR A COMPLETE MAINTENANCE SCHEDULE, CHECK YOUR OWNER'S MANUAL

Claims made based off testing and performance of Polaris HD Parts against standard OEM parts made by Polaris and competitor brands under normal use. For more information regarding Polaris HD parts including vehicle compatibility, installation and maintenance, please contact your authorized Polaris ORV dealer.

1000 / XP 1000 / XP KINETIC

ROOFS

WINDSHIELDS & REAR PANELS

DOORS

CAB COMFORT & CONVENIENCE

WINCHES

PROTECTION & AUDIO

STORAGE

XP KINETIC

MAINTENANCE PARTS & FLUIDS

# MAINTENANCE PARTS & FLUIDS

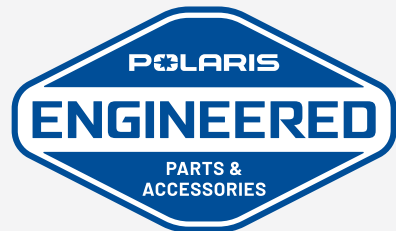

**POLARIS ENGINEERED PARTS AND OIL** have been validated and tested extensively, specifically for your vehicle. In order to maintain the peak performance of your Polaris vehicle only use official Polaris Engineered parts and oil.



We're taking the passion of our riders, workers, and outdoor enthusiasts to the next level with HD Parts. These Heavy Duty parts are engineered for riders who want greater durability and enhanced performance. HD Parts are designed and tested to handle greater wear and tear under all weather conditions.

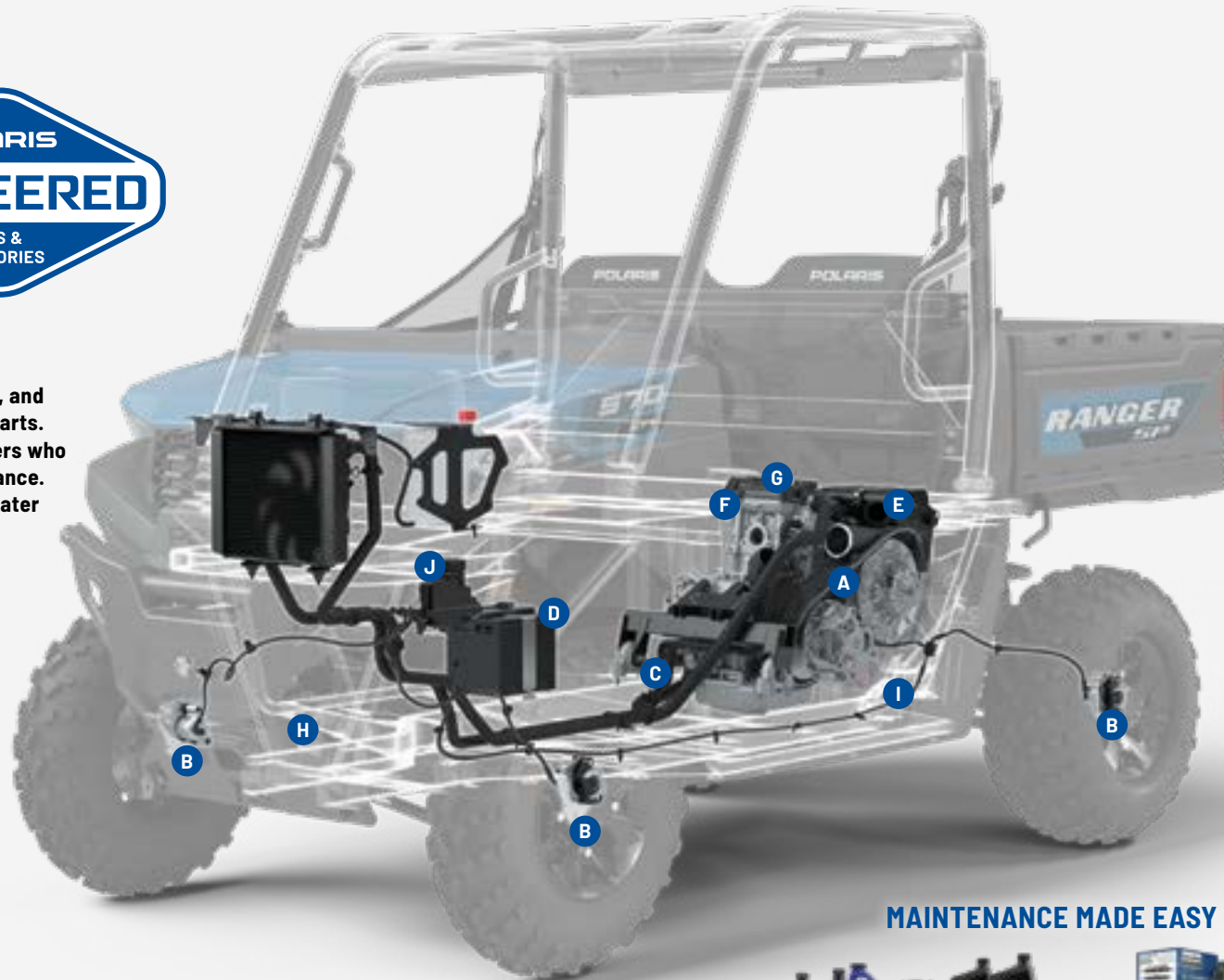

- A DRIVE BELT**  
» 3211218
- B BRAKE PADS**  
» 2203318  
» **HD** • 2208936
- C OIL FILTER**  
» 2540086  
» **HD** • 2252498
- D BATTERY**  
» 4014132-P  
» **HD** • 4081855
- E AIR FILTER**  
» 7082037
- F SPARK PLUG**  
» 3022662

**LOOKING FOR MORE SERVICE PARTS?**  
See P. 133 to learn how to find parts for your model.

## MAINTENANCE MADE EASY



**ORV MAINTENANCE KIT**  
Includes Oil Change Kit, Gearcase Fluids, Air Filter, & Spark Plug  
» 2891115  
SP 570 '22-26, CREW SP 570 '22-26



**OIL CHANGE KITS**  
2.5 QT Engine Oil (oil varies by kit), 1 Oil Filter (2540086) & 1 Drain Plug Washer  
» PS-4 • 2202166  
» PS-4 EXTREME • 2890056



**G ENGINE OIL** P. 128  
» PS-4 • 1QT • 2876244  
» PS-4 • 1GAL. • 2876245  
» PS-4 EXTREME • 1QT • 2889395  
» PS-4 EXTREME • 1GAL. • 2889396



**H DEMAND DRIVE FLUID**  
For front gearcase  
» 1QT • 2877922  
» 2.5 GAL. • 2877923



**I AGL**  
For transmission  
» 1QT • 2878068  
» 1GAL. • 2878069  
» EXTREME • 1QT • 2891028



**J DOT 4 BRAKE FLUID**  
» 12 OZ • 2872189



**ALL-SEASON GREASE TUBE**  
» 3 OZ • 2871322  
» 14 OZ • 2871423

## MAINTENANCE SCHEDULE\*

Claims made based off testing and performance of Polaris HD Parts against standard OEM parts made by Polaris and competitor brands under normal use. For more information regarding Polaris HD parts including vehicle compatibility, installation and maintenance, please contact your authorized Polaris ORV dealer.

### BREAK-IN MAINTENANCE

FIRST 25 HRS | 500 MI / 800 KM

- ENGINE OIL & OIL FILTER CHANGE
- FRONT GEARCASE CHANGE FLUID
- BATTERY TEST & CLEAN  
REPLACE AS NEEDED
- TRANSMISSION FLUID INSPECT  
ADD LUBRICANTS AS NEEDED

### 12 MONTHS

200 HRS | 2,000 MI / 3,200 KM

- ENGINE OIL & OIL FILTER CHANGE
- TRANSMISSION CHANGE FLUID
- FRONT GEARCASE CHANGE FLUID
- AIR FILTER REPLACE
- BRAKE PADS INSPECT  
REPLACE AS NEEDED

### 24 MONTHS

400 HRS | 4,000 MI / 6,400 KM

- ENGINE OIL & OIL FILTER CHANGE
- TRANSMISSION CHANGE FLUID
- FRONT GEARCASE CHANGE FLUID
- BRAKE FLUID CHANGE
- AIR FILTER REPLACE
- BRAKE PADS INSPECT  
REPLACE AS NEEDED

### 36 MONTHS

600 HRS | 6,000 MI / 9,700 KM

- ENGINE OIL & OIL FILTER CHANGE
- TRANSMISSION CHANGE FLUID
- FRONT GEARCASE CHANGE FLUID
- AIR FILTER REPLACE
- BRAKE PADS INSPECT  
REPLACE AS NEEDED

- BRAKE FLUID INSPECT  
ADD AS NEEDED
- DRIVE BELT INSPECT  
REPLACE AS NEEDED
- SPARK PLUGS INSPECT  
REPLACE AS NEEDED
- BATTERY TEST & CLEAN  
REPLACE AS NEEDED
- GENERAL LUBRICATION ALL FITTINGS, PIVOTS, CABLES, ETC.

- DRIVE BELT INSPECT  
REPLACE AS NEEDED
- SPARK PLUGS INSPECT  
REPLACE AS NEEDED
- BATTERY TEST & CLEAN  
REPLACE AS NEEDED
- GENERAL LUBRICATION ALL FITTINGS, PIVOTS, CABLES, ETC.

- BRAKE FLUID INSPECT  
ADD AS NEEDED
- DRIVE BELT INSPECT  
REPLACE AS NEEDED
- SPARK PLUGS INSPECT  
REPLACE AS NEEDED
- BATTERY TEST & CLEAN  
REPLACE AS NEEDED
- GENERAL LUBRICATION ALL FITTINGS, PIVOTS, CABLES, ETC.

FOR A COMPLETE MAINTENANCE SCHEDULE, CHECK YOUR OWNER'S MANUAL



\*This is a sample maintenance schedule. Please reference and use your owners manual for full maintenance and vehicle care.

# MAINTENANCE PARTS & FLUIDS

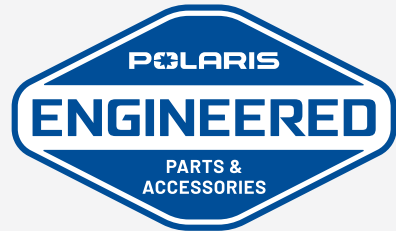

**POLARIS ENGINEERED PARTS AND OIL** have been validated and tested extensively, specifically for your vehicle. In order to maintain the peak performance of your Polaris vehicle only use official Polaris Engineered parts and oil.



We're taking the passion of our riders, workers, and outdoor enthusiasts to the next level with HD Parts. These Heavy Duty parts are engineered for riders who want greater durability and enhanced performance. HD Parts are designed and tested to handle greater wear and tear under all weather conditions.

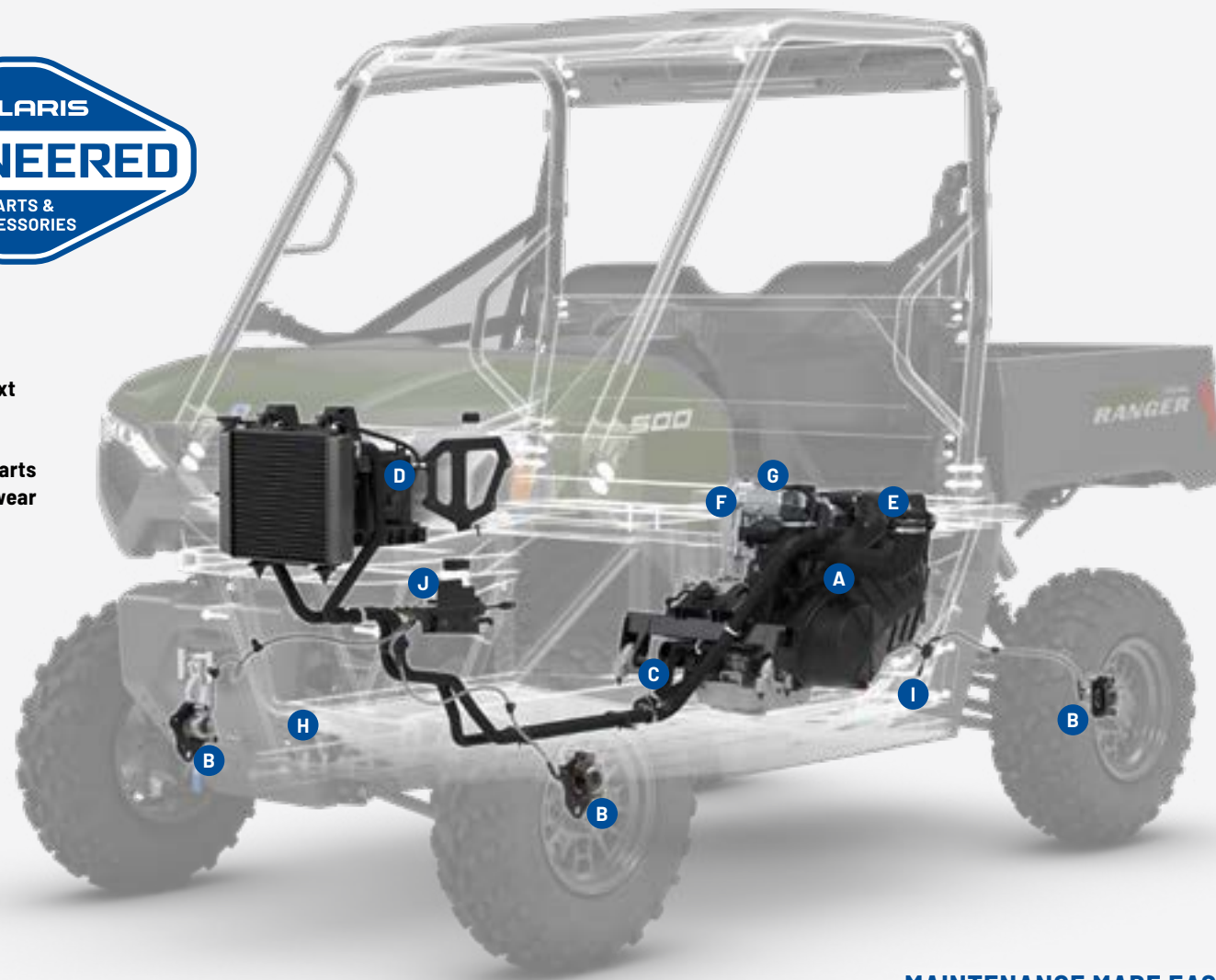

- A DRIVE BELT**  
» 3211077
- B BRAKE PADS**  
» 2203318  
» HD • 2208936
- C OIL FILTER**  
» 2540086  
» HD • 2522498
- D BATTERY**  
» 4017419
- E AIR FILTER**  
» 7082037
- F SPARK PLUG**  
» 3022662

**LOOKING FOR MORE SERVICE PARTS?**  
See P. 133 to learn how to find parts for your model.

**G ENGINE OIL** P. 128  
 » PS-4 • 1QT • 2876244  
 » PS-4 • 1GAL. • 2876245  
 » PS-4 EXTREME • 1QT • 2889395  
 » PS-4 EXTREME • 1GAL. • 2889396

**H ANGLE DRIVE FLUID**  
 For front gearcase  
 » 1QT • 2889280

**I AGL**  
 For transmission  
 » 1QT • 2878068  
 » 1GAL. • 2878069  
 » EXTREME • 1QT • 2891028

**J DOT 4 BRAKE FLUID**  
 » 12 OZ • 2872189

### MAINTENANCE MADE EASY

**OIL CHANGE KITS**  
 2.5 QT Engine Oil (oil varies by kit), 1 Oil Filter (2540086) & 1 Drain Plug Washer  
 » PS-4 • 2202166  
 » PS-4 EXTREME • 2890056

**ALL-SEASON GREASE TUBE**  
 » 3 OZ • 2871322  
 » 14 OZ • 2871423

Claims made based off testing and performance of Polaris HD Parts against standard OEM parts made by Polaris and competitor brands under normal use. For more information regarding Polaris HD parts including vehicle compatibility, installation and maintenance, please contact your authorized Polaris ORV dealer.

## MAINTENANCE SCHEDULE\*

BREAK-IN MAINTENANCE	12 MONTHS	24 MONTHS	36 MONTHS
<p><b>FIRST 25 HRS   500 MI / 800 KM</b></p> <ul style="list-style-type: none"> <li>ENGINE OIL &amp; OIL FILTER CHANGE</li> <li>BATTERY TEST &amp; CLEAN REPLACE AS NEEDED</li> <li>FRONT GEARCASE CHANGE FLUID</li> <li>TRANSMISSION FLUID INSPECT ADD LUBRICANTS AS NEEDED</li> </ul>	<p><b>200 HRS   2,000 MI / 3,200 KM</b></p> <ul style="list-style-type: none"> <li>ENGINE OIL &amp; OIL FILTER CHANGE</li> <li>HD MODELS ONLY TRANSMISSION CHANGE FLUID</li> <li>FRONT GEARCASE CHANGE FLUID</li> <li>AIR FILTER REPLACE</li> <li>BRAKE PADS REPLACE AS NEEDED</li> </ul>	<p><b>400 HRS   4,000 MI / 6,400 KM</b></p> <ul style="list-style-type: none"> <li>ENGINE OIL &amp; OIL FILTER CHANGE</li> <li>HD MODELS ONLY TRANSMISSION CHANGE FLUID</li> <li>FRONT GEARCASE CHANGE FLUID</li> <li>BRAKE FLUID CHANGE</li> <li>AIR FILTER REPLACE</li> <li>BRAKE PADS INSPECT REPLACE AS NEEDED</li> </ul>	<p><b>600 HRS   6,000 MI / 9,700 KM</b></p> <ul style="list-style-type: none"> <li>ENGINE OIL &amp; OIL FILTER CHANGE</li> <li>HD MODELS ONLY TRANSMISSION CHANGE FLUID</li> <li>FRONT GEARCASE CHANGE FLUID</li> <li>AIR FILTER REPLACE</li> <li>BRAKE FLUID INSPECT ADD AS NEEDED</li> </ul>
	<ul style="list-style-type: none"> <li>BRAKE FLUID INSPECT ADD AS NEEDED</li> <li>DRIVE BELT INSPECT REPLACE AS NEEDED</li> <li>SPARK PLUGS INSPECT REPLACE AS NEEDED</li> <li>BATTERY TEST &amp; CLEAN REPLACE AS NEEDED</li> <li>GENERAL LUBRICATION ALL FITTINGS, PIVOTS, CABLES, ETC.</li> </ul>	<ul style="list-style-type: none"> <li>DRIVE BELT INSPECT REPLACE AS NEEDED</li> <li>SPARK PLUGS INSPECT REPLACE AS NEEDED</li> <li>BATTERY TEST &amp; CLEAN REPLACE AS NEEDED</li> <li>GENERAL LUBRICATION ALL FITTINGS, PIVOTS, CABLES, ETC.</li> </ul>	<ul style="list-style-type: none"> <li>BRAKE PADS INSPECT REPLACE AS NEEDED</li> <li>SPARK PLUGS INSPECT REPLACE AS NEEDED</li> <li>BATTERY TEST &amp; CLEAN REPLACE AS NEEDED</li> <li>DRIVE BELT INSPECT REPLACE AS NEEDED</li> <li>GENERAL LUBRICATION ALL FITTINGS, PIVOTS, CABLES, ETC.</li> </ul>

FOR A COMPLETE MAINTENANCE SCHEDULE, CHECK YOUR OWNER'S MANUAL



# RANGER 150 EFI



### YOUTH CRAWLER TIRE

- Premium durability to ride longer
- Increased ground clearance and performance
- » 22" x 8" R12 • 5416945
- » 22" x 10" R12 • 5416944



### YOUTH BUCKLE WHEEL

- » FRONT • 12" x 7" • 1524114
- » REAR • 12" x 8" • 1524115



### PRO ARMOR WHEEL & TIRE KIT: YOUTH CRAWLER & BUCKLE

- » 2885154



### FULL WINDSHIELD - POLY

- .25" clear poly carbonate
- Mounts with Lock & Ride
- » 2889854



### HALF WINDSHIELD - POLY

- 13" tall to provide protection and allow airflow
- .25" clear poly carbonate
- Mounts with Lock & Ride
- » 2889855

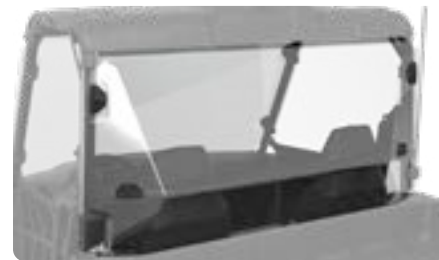

### REAR PANEL - POLY

- .25" clear poly carbonate
- Mounts with Lock & Ride
- » 2889856



### FRONT & REAR BUMPER SET

- Durable, e-coated steel construction
- Front and Rear Bumper included
- » 2883287



### SPORT ROOF - POLY

- Stay protected from rain, snow and sun
- Easily installs
- » 2883289



### ROOF, WINDSHIELD, BACK PANEL KIT

- Provides extra protection
- Quick and easy installation with included hardware
- Windshield: 1/8" Hardcoat Scratch Resistant Polycarbonate
- Roof: 1/8" HMW Haircell Polyethylene
- Back Panel: 1/8" Polycarbonate
- » 2150

## MAINTENANCE PARTS & FLUIDS

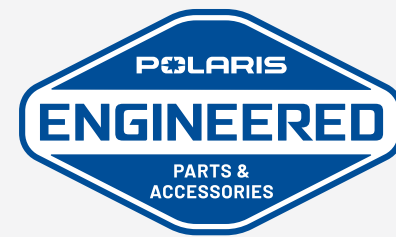

### POLARIS ENGINEERED PARTS AND OIL

have been validated and tested extensively, specifically for your vehicle. In order to maintain the peak performance of your Polaris vehicle only use official Polaris Engineered parts and oil.



**DRIVE BELT**  
» 3050270  
150 EFI '18-26



**BRAKE PADS**  
» FRONT • 1912970  
» REAR • 1912971  
150 EFI '18-26



**OIL FILTER**  
» 3023344  
150 EFI '18-26



**BATTERY**  
» 4010678  
150 EFI '18-26



**AIR FILTER**  
» 7082249  
150 EFI '18-26



**SPARK PLUGS**  
» 3050051  
150 EFI '18-26



**ENGINE OIL**  
SEE P. 128 FOR DETAILS



**ANGLE DRIVE FLUID**  
» 1QT • 2889280



**DEMAND DRIVE FLUID**  
» 1QT • 2877922  
» 2.5 GAL. • 2877923



**AGL**  
» 1QT • 2878068  
» 1 GAL. • 2878069  
» EXTREME • 1QT • 2891028



**DOT 4 BRAKE FLUID**  
» 12 OZ • 2872189



**ALL-SEASON GREASE TUBE**  
» 3 OZ • 2871322  
» 14 OZ • 2871423

## MAINTENANCE SCHEDULE\*

### BREAK-IN MAINTENANCE

- FIRST 5 HRS | 50 MI / 80 KM
- ENGINE OIL & OIL FILTER CHANGE
  - DRIVE CHAIN ADJUST & LUBRICATE
  - BRAKE PAD INSPECT  
REPLACE AS NEEDED

### 6 MONTHS

- 25 HRS | 500 MI / 800 KM
- ENGINE OIL & OIL FILTER CHANGE
  - BATTERY TEST & CLEAN  
REPLACE AS NEEDED
  - GENERAL LUBRICATION ALL FITTINGS, PIVOTS, CABLES, ETC.

### 12 MONTHS

- 50 HRS | 1000 MI / 1600 KM
- ENGINE OIL & OIL FILTER CHANGE
  - BATTERY TEST & CLEAN  
REPLACE AS NEEDED

### 18 MONTHS

- 75 HRS | 1,500 MI / 2,500 KM
- ENGINE OIL & OIL FILTER CHANGE
  - BATTERY TEST & CLEAN  
REPLACE AS NEEDED

### 24 MONTHS

- 100 HRS | 2,000 MI / 3,200 KM
- ENGINE OIL & OIL FILTER CHANGE
  - TRANSMISSION CHANGE FLUID
  - DRIVE BELT INSPECT  
REPLACE AS NEEDED
  - SPARK PLUG INSPECT  
REPLACE AS NEEDED
  - BATTERY TEST & CLEAN  
REPLACE AS NEEDED

FOR A COMPLETE MAINTENANCE SCHEDULE, CHECK YOUR OWNER'S MANUAL



\*This is a sample maintenance schedule. Please reference and use your owners manual for full maintenance and vehicle care.